

LUBRICATION ORDER

LO 5-4310-345-12

16 DECEMBER 83

(Supersedes LO 5-4310-345-12, 1 MARCH 1973)

COMPRESSOR, ROTARY, AIR; DIESEL ENGINE DRIVEN, 250 CFM, 100 PSI; TRAILER MTD; TWO WHEEL (DAVEY MODEL 14M250RPV) (NSN 4310-00-256-9319) COMPONENT OF PNEUMATIC TOOL AND COMPRESSOR OUTFIT (3820-00-950-8584)

Reference: TM 5-4310-345-14 and FEDERAL SUPPLY CATALOG C9100-IL.

Intervals (on-condition or hard time) and the related man-hour times are based on normal operation. The man-hour time specified is the time you need to do all the services prescribed for a particular interval. On condition (OC) oil sample intervals shall be applied unless changed by the Army Oil Analysis Program (AOAP) laboratory. Change the hard time interval if your lubricants are contaminated or if you are operating the equipment under adverse operating conditions, including longer-than-usual operating hours. The hard time interval may be extended during periods of low activity. If extended, adequate preservation precautions must be taken. Hard time intervals will be applied in the event AOAP laboratory support is not available.

WARNING

Dry cleaning fluid is flammable. Do not use near a flame or excessive heat. Use only with adequate ventilation. Avoid prolonged breathing of vapors and minimize skin contact.

*The time specified is the time required to perform all services at the particular interval (on-condition or hard times).

● TOTAL MAN-HOURS		● TOTAL MAN-HOURS	
INTERVAL	MAN-HOURS	INTERVAL	MAN-HOURS
10	0.1	500	0.6
100	0.7	4000	3.6

TA 220097

Clean parts or fittings with dry cleaning solvent (SD), Type II or equivalent. Dry before lubricating. Dotted arrow shafts indicate lubrication on both sides of equipment. A dotted circle indicates a drain below. Relubricate all items found contaminated after fording or washing.

The lowest level of maintenance authorized to lubricate a point is indicated by one of the following symbols as appropriate: Operator/Crew (C); and Organizational Maintenance (O).

Reporting errors and recommending improvements. You can help improve this manual. If you find any mistakes, or if you know of a way to improve the procedures, please let us know. Mail your letter or DA Form 2028 (Recommended Changes to Publications and Blank Forms) direct to: Commander, US Army Tank-Automotive Command, ATTN: DRSTA-MB, Warren, MI 48090. A reply will be furnished to you.

LUBRICANT • INTERVAL

INTERVAL • LUBRICANT

- Generator
(No lubrication required)
- Crankcase Oil Drain Plug (O)
(Drain and refill)
(See Notes 1 and 4)
- Starter
(No lubrication required)
- Tachometer Drive (O)
(Sparingly)

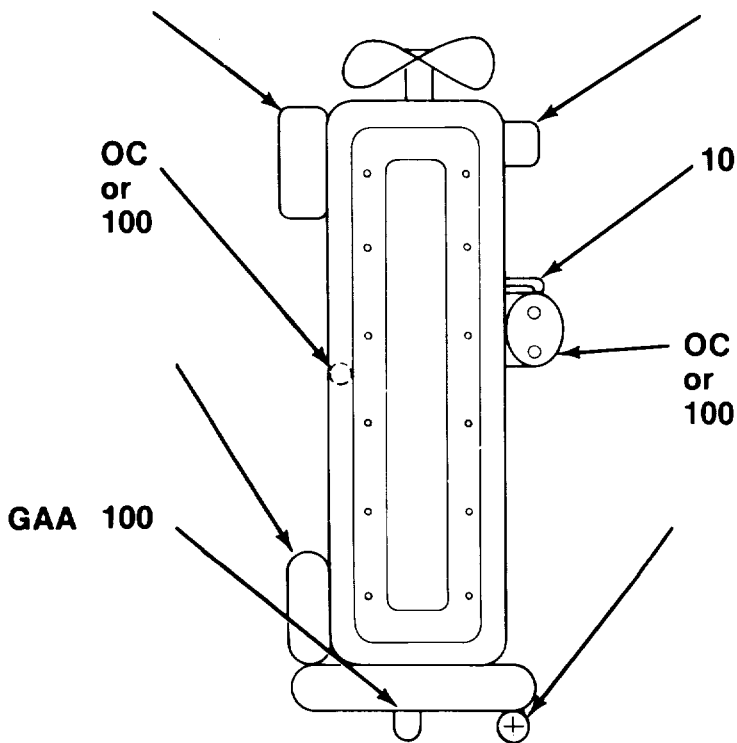

- Water Pump
(No lubrication required)
- Crankcase Oil Dipstick (C)
(Check level)
(See Note 5)
- Crankcase Oil Filter (O)
(Replace element)
(See Notes 1 and 6)
- Crankcase Oil Filler Cap (C)
(See Key)

ENGINE

- Compressor Oil Filter (O)
(Replace element)
(See Note 9)
- Oil Separator Drain Valve (C)
(Drain and refill)
(See Note 8)
- Oil Separator Dipstick (C)
(Check level)
(See Note 7)

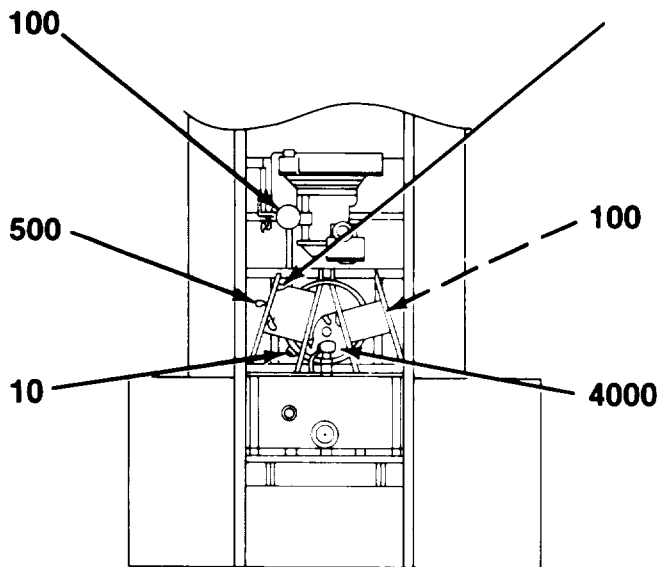

- Oil Separator Fill Plug (O)
(See Key)
- Hose Reel (O)
(Sparingly)
- Oil Separator Element (O)
(See Note 10)

WARNING

Do not remove dipstick while compressor is in operation.

WARNING

Remove and destroy separator element every 4000 hours.

COMPRESSOR

KEY -

LUBRICANTS	CAPACITY	EXPECTED TEMPERATURES			INTERVALS
		Above +15°F (Above -9°C)	+40° to -15°F (+4° to -26°C)	+40° to -65°F (+4° to -54°C)	
OE/ HDO - Lubricating Oil, Internal Combustion Engine, Tactical Service OEA - Lubricating Oil, Internal Combustion, Arctic - Oil Can Points (See Note 2) - Engine Crankcase - Compressor Oil, Separator	15 qts. (14.2 L) 32 qts. (30.3 L)	OE/HDO 30	OE/HDO 10	OEA (See Note 1)	For Arctic operation refer to FM 9-207 OC - On Condition (AOAP) Intervals given are in hours of normal operation.
GAA - Grease, Automotive and Artillery		ALL TEMPERATURES			

*See Note 11 for lubricant specification number.

NOTES:

1. ARMY OIL ANALYSIS PROGRAM (AOAP). For active Army units, obtain samples from engine and automatic transmission every 50 hours of operation or 60 days (whichever comes first). Reserve and National Guard activities will use 50 hours or 120 days as the prescribed sample intervals. Reserve and National Guard equipment in frequent use during active training period will adhere to the schedule for Active Army units. As a minimum, one sample from each units' two week active training period will be submitted for each item of equipment. Send these samples to the nearest AOAP laboratory. Refer to TB 43-0210 for sampling instructions. When or if AOAP laboratory support is unavailable, hard time intervals will apply.

NOTE

Do not hold oil samples. Submit oil

samples as soon as they have been taken.

Seasonal oil changes will be made due to expected temperatures. (See Key.)

2. FOR OPERATION OF EQUIPMENT IN PROTRACTED COLD TEMPERATURES BELOW -15°F (-26°C). Remove lubricants prescribed in Key for temperatures above -15°F (-26°C). Relubricate with lubricants specified in Key for temperatures below -15°F (-26°C). If OEA lubricant is required to meet the temperature ranges prescribed in the Key, OEA lubricant is to be used in place of OE/HDO-10 lubricant for all temperature ranges where OE/HDO-10 is specified in the Key.

3. OIL CAN POINTS. Each 50 hours lubricate control linkage, hinges, and all exposed adjusting threads with OE/HDO.

NOTES - CONTINUED:

4. ENGINE. Oil is to be changed each time an engine oil change is directed by AOAP laboratory. When AOAP laboratory support is not available, change oil each 100 hours. Drain when oil is warm.

5. ENGINE OIL LEVEL CHECK. Engine oil level should be between high and low marks on dipstick (allow to set 5 minutes before checking).

6. ENGINE OIL FILTER. Filter is to be replaced each time an engine oil change is directed by AOAP laboratory. After installing new filter element, fill crankcase, operate engine 5 minutes, check housing for leaks, check crankcase oil level and bring to full mark. When AOAP laboratory support is not available, install new filter element each 100 hours.

7. OIL SEPARATOR LEVEL. Check level each 10 hours.

WARNING

Do not remove dipstick while compressor is in operation. Always relieve the air system of all air pressure before removing dipstick to check oil level.

8. OIL SEPARATOR. Each 500 hours change oil. Drain when lubricant is warm. After refill, operate for 5 minutes, check for leaks and bring to full mark. Observe warning given in Note 7.

9. COMPRESSOR OIL FILTER. Each 100 hours, remove filter element, clean housing and install new filter element. After installing new filter element, fill compressor, operate for 5 minutes, check for leaks and bring to full mark. Observe warning given in Note 7.

10. OIL SEPARATOR ELEMENT. Each 4,000 hours replace the oil separator element.

WARNING

Do not attempt to clean the element or re-use the element because of its clean appearance. Metal salts are deposited on the element as the oil is separated from the air. Pollution of metal salts on the element will lower the flash point and can cause a fire in the separator. Destroy used element to prevent accidental re-use.

11. The following is a list of lubricants with military symbols and applicable specification numbers.

OE/HDO	MIL-L-2104
GAA	MIL-G-10924
OEA	MIL-L-46167
(SD), Type II	P-D-680

Copy of this Lubrication Order will remain with the equipment at all times, instructions contained herein are mandatory.

By order of the Secretary of the Army:

JOHN A. WICKHAM, JR.
General, United States Army
Chief of Staff

OFFICIAL:

ROBERT M. JOYCE
Major General, United States Army
The Adjutant General

DISTRIBUTION:

To be distributed in accordance with DA Form 12-25A, Operator and Organizational maintenance requirements for Rotary Air Compressors.

TA 220100